

I2C addressing:  
 Light: 0b0101001 (0x29)  
 Pressure: 0b1110110 (0x76)  
 Temperature: 0b0011100 (0x1C)  
 Accelerometer: 0b0011001 (0x19)

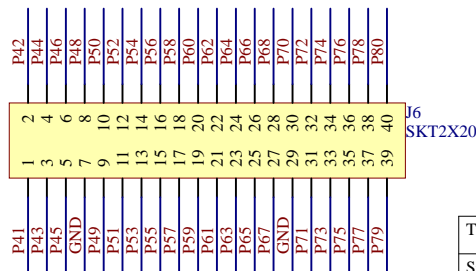

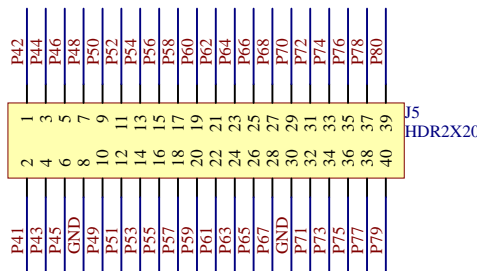

Title Sensors			
Size A4	Project Chiliboard Sensor Sandwich	Rev 1.0.0	
Date 2016-08-26	Number 3	Sheet 3 / 2	

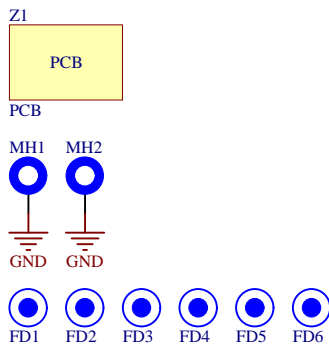
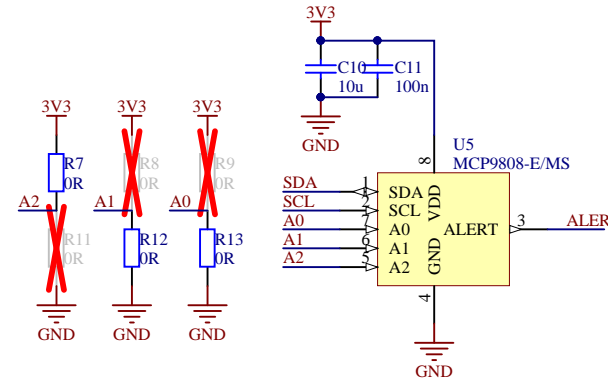
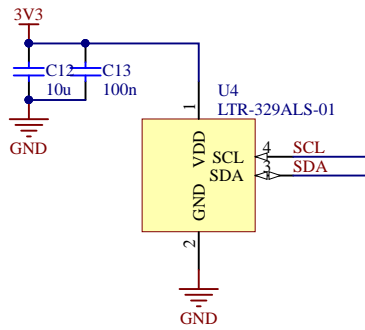
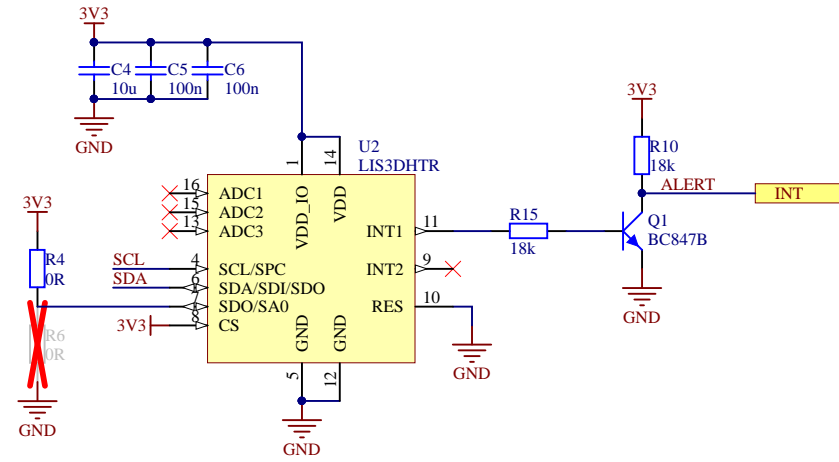
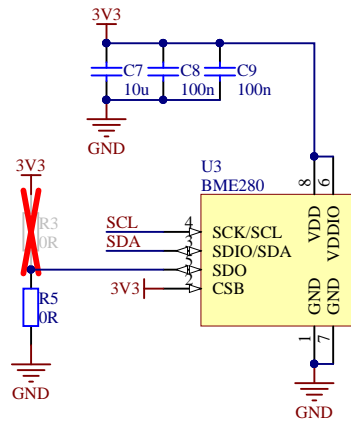